

Application list for AP900C

NEW update	Brand	Type	AP900C applicable starting from software version:	Note	Plug and Play	SVT files	CAN connection point	+15 (12V) connection points	Remark	Photo	
	Alfa	147 2002>								2	
		159								3	
		BC								2	
		159								3	
		Brera								3	
		Giulietta								2	
		GT								2	
	MiTo		F17.10H		190-5002130		OBD-II / Diagnostic Link Connector Pin 6 (CAN High) & Pin 14 (CAN Low)			3	
	Spider 2007>									3	
	Audi	A1	F18.01i		190-5002230	SVT-090	In bundle in steering column: orange/black (CAN High, twisted with orange/brown (CAN Low)				
		A2								7	
		A2 1.2TDI, 1.4TDI								7	
		A3 (8P) manual 2009>	F17.10H		190-5002450		Wire bundle under clock-unit, orange/blue (CAN High) twisted with orange/brown (CAN Low)			10	
		A3 (8P) automatic 2009>	F17.06D		190-5002450		Wire bundle under clock-unit, orange/blue (CAN High) twisted with orange/brown (CAN Low)			10	
		A4 (8K) 2008>	F17.10H		190-5002450		In steering column orange/blue (CAN High), twisted with orange/brown (CAN Low)				
		A5									
		A6 2006>								10	
		Q5									
		Q7								7	
	R8										
	TT								10		
	BMW	1-series (E87) 2004-2011	F18.01i		190-5002470		Behind glove box in open taped bundle: blue/red (CAN High), twisted with red (CAN Low)			18	
		1-series (F20) 2011>									
		3-series (E90N, E91N, E92N, E93N) 2008-2012	F18.01i		190-5002470		Behind glove box in open taped bundle: blue/red (CAN High), twisted with red (CAN Low)			18	
		5-series (E60-E61) 2003>	F18.01i		190-5002470		51-pin connector behind glove compartment, position 35 or 29, blue/red (CAN High) and position 34 or 30, red (CAN Low)			18	
		6-series (E63-E64) 2004>								18	
		7-series (E65) 2001>								18	
		X1 (E84) 2009>	F18.01i		190-5002470		Behind glove box in open taped bundle: blue/red (CAN High), twisted with red (CAN Low)	DLC position 1		18	
NEW	X5 (E70) 2007-2013	F18.01i		190-5002470		In bundle below passenger floor-well trim (see photos), blue/red (CAN High) twisted with red (CAN Low)			18		
	Cadillac	BLS								3	
NEW	Chevrolet	Aveo 2012->	F18.02K		190-5002160		OBD-II / Diagnostic Link Connector Pin 6 (CAN High) & Pin 14 (CAN Low)			25	
		Captiva 2012->	F18.02K		190-5002390	SVT-115	OBD-II / Diagnostic Link Connector Pin 6 (CAN High) & Pin 14 (CAN Low)			20	
		Colorado automatic 2009-2011	F17.07E		190-5002480		OBD-II / Diagnostic Link Connector Pin 6 (CAN High) & Pin 14 (CAN Low)				
		Colorado manual gearbox 2009-2011			pre-program SVT-file	190-5002480	SVT 037a	OBD-II / Diagnostic Link Connector Pin 6 (CAN High) & Pin 14 (CAN Low)			24
		Colorado automatic 2012>			pre-program SVT-file	190-5002130	SVT 120a	OBD-II / Diagnostic Link Connector Pin 6 (CAN High) & Pin 14 (CAN Low)			14
		Colorado manual gearbox 2012>	F18.02K		190-5002130	SVT 120	OBD-II / Diagnostic Link Connector Pin 6 (CAN High) & Pin 14 (CAN Low)			14	
		Cruze LT 2009->	F17.06B		190-5002130		OBD-II / Diagnostic Link Connector Pin 6 (CAN High) & Pin 14 (CAN Low)	5-pole connector behind ignition lock, purple/black		3	
		Orlando (manual gearbox)	F17.06B		190-5002130		OBD-II / Diagnostic Link Connector Pin 6 (CAN High) & Pin 14 (CAN Low)	5-pole connector behind ignition lock, purple/black		3	
		Spark 2009>									
		Chrysler	PT Cruiser								19
	Sebring									6	
	Voyager CRD 2006 - 2007									24	
	Grand Voyager 2008>									25	
	Citroen	Berlingo 2006-2008								8	
		Berlingo 2009>	F17.04T		190-500041B	SVT-016	OBD-II / Diagnostic Link Connector Pin 6 (CAN High) & Pin 14 (CAN Low)			16	
		C1								16	
		C1 Petrol								11	
		C2 2006->								16	
		C3 2006-2008								16	
		C3 2009>	F17.06D		190-500041B		OBD-II / Diagnostic Link Connector Pin 6 (CAN High) & Pin 14 (CAN Low)			6	
		C4 <2008								1	
		C4 Picasso <2008								16	
		C4 2009>	F17.06D		190-500041B		OBD-II / Diagnostic Link Connector Pin 6 (CAN High) & Pin 14 (CAN Low)				
		C4 Picasso 2009>	F17.06D		190-500041B		OBD-II / Diagnostic Link Connector Pin 6 (CAN High) & Pin 14 (CAN Low)				
		C5 2005-2007								16	
		C5 2008>									
		C8								8	
		C-Crosser	F17.09G		190-5002360		OBD-II / Diagnostic Link Connector Pin 6 (CAN High) & Pin 14 (CAN Low)	Ignition lock 6-pin WHT connector pin 2		6	
	C-zero	F18.01i		190-5002360		OBD-II / Diagnostic Link Connector Pin 6 (CAN High) & Pin 14 (CAN Low)			6		
	Jumper / Relay Multijet 2006-2010	F17.10E		190-5002110		Use LITE-ON OBD-II plug (LTK 0000130) or Blue 36-pole connector on rear side of body computer, green part, position 6: brown/black or black/pink (CAN High) & position 5 orange or white/pink (CAN Low).	Ignition lock ORG/BLK		2		
	Jumper / Relay type 250 2.3 Multijet 2010>	F17.10H		190-5002130	SVT-077	Use LITE-ON OBD-II plug (LTK 0000130) or OBD-II / Diagnostic Link Connector Pin 6 (CAN High) & Pin 14 (CAN Low)	Ignition lock ORG/BLK	Mount LITE-ON Clutch Switch	3		
	Jumpy / Despatch 2009>	F18.07K		190-500041B	SVT-119	OBD-II / Diagnostic Link Connector Pin 6 (CAN High) & Pin 14 (CAN Low)			25		
	Nemo 2008>	F17.09G		190-5002110		OBD-II / Diagnostic Link Connector Pin 6 (CAN High) & Pin 14 (CAN Low)		Mount purple wire to Original Clutch Switch	2		
	Picasso 2006>								16		
	Dacia	Dokker								3	
		Duster								7	
		Logan								7	
		Logdy	F18.07K		190-5002180	SVT-121	OBD-II / Diagnostic Link Connector Pin 6 (CAN High) & Pin 14 (CAN Low)			12	
		Sandero II Stepway 2012->	F18.03L		190-5002180	SVT-124	OBD-II / Diagnostic Link Connector Pin 6 (CAN High) & Pin 14 (CAN Low)			7	
	Dodge	Avenger								6	
		Caliber								6	
		Journey								6	
		Nitro								25	
		Ram Van CRD 2006-2007								24	
	Fiat	500 manual	F17.06B		190-5002380	SVT117 (rev.2)	OBD-II / Diagnostic Link Connector Pin 6 (CAN High) & Pin 14 (CAN Low)	Ignition lock 4-pin connector, pin-2 BLU wire		20	
		500 duo-logic	F18.01i		190-5002380	SVT105	OBD-II / Diagnostic Link Connector Pin 6 (CAN High) & Pin 14 (CAN Low)	Ignition lock 4-pin connector, pin-2 BLU wire		20	

NEW	Brand	Type	AP900C applicable starting from software version:	Note	Plug and Play	SVT files	CAN connection point	+15 (12V) connection points	Remark	Photo
	Renault	Clio III 05/2009>	F17.06D		190-5002180		ODB-II / Diagnostic Link Connector Pin 6 (CAN High) & Pin 14 (CAN Low)			12
		Estace								7
		Fluence								12
		Kango DCI 2008>	F17.04T		190-5002180		ODB-II / Diagnostic Link Connector Pin 6 (CAN High) & Pin 14 (CAN Low)			12
		Koleos								12
		Laguna 2007>								7
		Master 2003-2010	F17.05B		190-5002140	SVT015	ODB-II / Diagnostic Link Connector Pin 6 (CAN High) & Pin 14 (CAN Low)			12
		Master 2010>	F17.09G		190-5002180	SVT059	ODB-II / Diagnostic Link Connector Pin 6 (CAN High) & Pin 14 (CAN Low)	12V (+15) DLC position 1, yellow		7
		Master 2012> (right hand drive)	F17.09G		190-5002430	SVT059	ODB-II / Diagnostic Link Connector Pin 6 (CAN High) & Pin 14 (CAN Low)	12V (+15) DLC position 1, yellow		12
		Maxity								12
		Megane 2009>								12
		Modus / Grand Modus								12
		Scenic 2008>								7
		Trafic DCI 2006-2010	F17.05B		190-5002140	SVT015	ODB-II / Diagnostic Link Connector Pin 6 (CAN High) & Pin 14 (CAN Low)			7
		Trafic DCI 2011>	F17.10H		190-5002140	SVT070	ODB-II / Diagnostic Link Connector Pin 6 (CAN High) & Pin 14 (CAN Low)			7
		Twingo II petrol 2007>	F17.06D		190-5002430		ODB-II / Diagnostic Link Connector Pin 6 (CAN High) & Pin 14 (CAN Low)			12
update		Twingo II 1.5DCI 2007>	F17.06D		190-5002180		ODB-II / Diagnostic Link Connector Pin 6 (CAN High) & Pin 14 (CAN Low)			12
	Saab	9-3 2002>	F17.05C		190-5002130		ODB-II / Diagnostic Link Connector Pin 6 (CAN High) & Pin 14 (CAN Low)			3
NEW	Seat	Alhambra (7N) 2010- Altea 2004>> Exeo	F18.01J		190-5002450	SVT109	Under steering column twisted pair green/white (CAN High), green (CAN Low)			10
		Ibiza 2008> Leon 2006>								7
		Mii (AA)	F18.01J		190-5002450	SVT111	with position 29 orange/brown (CAN Low)			10
	Skoda	Citigo	F18.01J		190-5002450	SVT111	with position 29 orange/brown (CAN Low)			10
NEW		Fabia 2006>								7
NEW		Octavia 2004>	F18.02J		190-5002450		Orange/Purple (high) and Orange/Green (low) rear of instrument cluster			10
		Rapid 2012>	F18.02J		190-5002230					7
		Roomster								7
		Roomster 1.4TDI, 1.9TDI								7
		Superb								10
		Yeti								3
	Smart	ForFour ForTwo 2007> Roadster 2006>								21
	Ssang Yong	Actyon A200 Xdi Actyon A230 Kyrion M200Xdi Rexton 2006> Rexton 230 Rexton 270 Rodius 270								2
										2
										2
										18
										2
										2
	Subaru	Forester 2.0 Forester 2008> Impreza 1.5, 2.0 R Impreza 2.5 WRX Impreza (2007>) Legacy (Outback) 2003> Outback Trezia	F17.10H		190-5002280		ODB-II / Diagnostic Link Connector Pin 6 (CAN High) & Pin 14 (CAN Low)			11
		Tribeca WRX STI XV XV CVT	F18.01J		190-5002220	SVT112	ODB-II / Diagnostic Link Connector Pin 6 (CAN High) & Pin 14 (CAN Low)			11
			F18.01J		190-5002220	SVT112a	ODB-II / Diagnostic Link Connector Pin 6 (CAN High) & Pin 14 (CAN Low)			11
	Suzuki	Alto 2009> Alto 1.0 Automatic 2009> Grand Vitara 2006>	F17.04T F17.09G		190-5002210 190-5002210		ODB-II / Diagnostic Link Connector Pin 6 (CAN High) & Pin 14 (CAN Low) ODB-II / Diagnostic Link Connector Pin 6 (CAN High) & Pin 14 (CAN Low)		Mount AA170 or AA177 Clutch Switch	13
						SVT058			Mount AA170 or AA177 Clutch Switch	13
		Jimny	F17.10H		190-5002210		ODB-II / Diagnostic Link Connector Pin 6 (CAN High) & Pin 14 (CAN Low)			3
		Kozashi	F17.06D		190-5002210		ODB-II / Diagnostic Link Connector Pin 6 (CAN High) & Pin 14 (CAN Low)			13
		Splash	F17.04T		190-5002210	SVT007	ODB-II / Diagnostic Link Connector Pin 6 (CAN High) & Pin 14 (CAN Low)		Mount purple wire to Original Clutch Switch	13
		Swift 2008-2010	F17.04T		190-5002210	SVT110	ODB-II / Diagnostic Link Connector Pin 6 (CAN High) & Pin 14 (CAN Low)			13
		Swift 2010- manual + automatic gearbox	F18.01J		190-5002210		ODB-II / Diagnostic Link Connector Pin 6 (CAN High) & Pin 14 (CAN Low)		Mount purple wire to Original Clutch Switch.	13
		SX4 / Liana 2006>	F17.04T		190-5002210		ODB-II / Diagnostic Link Connector Pin 6 (CAN High) & Pin 14 (CAN Low)			13
	Toyota	Auris Petrol 2007-2012 Auris Petrol 2013- Auris 2013 Auris Hybrid 2010> Avenis 2009 > manual gearbox Aygo Petrol 2008> Camry petrol 2008> Corolla Sedan Petrol 2007> Hi-ace iQ	F17.06D F17.10H F17.05B		190-5002220 190-5002280 190-5002220	SVT031 SVT079	ODB-II / Diagnostic Link Connector Pin 6 (CAN High) & Pin 14 (CAN Low) ODB-II / Diagnostic Link Connector Pin 6 (CAN High) & Pin 14 (CAN Low) ODB-II / Diagnostic Link Connector Pin 6 (CAN High) & Pin 14 (CAN Low) ODB-II / Diagnostic Link Connector Pin 6 (CAN High) & Pin 14 (CAN Low) ODB-II / Diagnostic Link Connector Pin 6 (CAN High) & Pin 14 (CAN Low)		Mount purple wire to Original Clutch Switch.	11
										28
										11
										11
										11
										11
										5
										11
										5
										13
										13
										11
										5
										13
										26
										13
										11
										11
										5
										28
										11
										28
										11
										28
										28
	Volkswagen	Amarok Beetle	F18.01I		190-5002230	SVT090	In bundle in steering column: orange/black (CAN High, twisted with orange/brown (CAN Low)			7

Application list for AP900

NEW update	Brand	Type	Note	Plug and Play	Universal harness	Remark	Photo
	Alfa	147 <2000			190-500225W		
		147 2000>		190-5002110			2
		156 <2002			190-500225W		
		156 2002>		190-5002110			2
		156 Crosswagon		190-5002110			2
		159		190-5002130			3
		8C					
		Brera		190-5002130			3
		Guilietta 2010>		190-5002130			
		GT		190-5002110			2
	MiTo		190-5002130			3	
	Spider 2007>		190-5002130			3	
	Audi	A1		190-5002230			
		A2		190-5002230			7
		A2 1.2TDI, 1.4TDI		190-5002310			7
		A3 <2005		190-5002230			7
		A3 TDI <2005		190-5002310			7
		A3 2005>		190-5002450			10
		A4 2001-2007		190-5002230			7
		A4 1.9&2.5 TDI 2001- 2007		190-5002310			7
		A4 2008>		190-5002450			7
		A5		190-5002450			10
		A6 <2006		190-5002230			7
		A6 1.9&2.5 TDI <2006		190-5002310			7
		A6 2006>		190-5002450			10
		A7		190-5002450			10
		Q5		190-5002450			
		Q7		190-5002230			7
	R8		190-5002450				
	TT		190-5002450			10	
	BMW	1-series (E87) 2004-2011		190-5002470			18
		3-series (E90) 2005-2012		190-5002470			18
		5-series (E60-E61) 2003-		190-5002470			18
		6-series (E63-E64) 2004-		190-5002470			18
		7-series (E65) 2001-		190-5002470			18
	Buick	Enclave		190-5002390			20
		Lacrosse		190-5002130			3
		Regal		190-5002130			3
	Cadillac	BLS		190-5002130			3
		Escalade		190-5002390			20
	Chery	J3 2011-			190-500225W		
		J11 2011-				190-500225W	
	Chevrolet	Avalanche		190-5002390			20
		Aveo	Drive-by-wire models (E-gas) only	190-5002400			2
		Camaro		190-5002390			20
		Captiva 2.0 VCDI		190-5002390			20
		Captiva 2.4 4WD		190-5002390			20
		Cobalt		190-5002390			20
		Colorado 2009-2011		190-5002480			24
		Colorado 2012-		190-5002130			
		Corvette		190-5002390			20
		Epica VCDI		190-5002390			20
		Express		190-5002390			20
		HHR		190-5002130			3
		Impala		190-5002390			20
		Lacetti		190-5002400			2
		Malibu		190-5002390			20
		Nubira TCDI		190-5002400			2
		Silverado		190-5002390			20
		Spark	Drive-by-wire models (E-gas) only	190-5002160			25
		Suburban		190-5002390			20
	Tahoe		190-5002390			20	
	Traverse		190-5002390			20	
	Chrysler	PT Cruiser 2000-2006			190-500225W		19
		PT Cruiser 2006>		190-5002160			25
		Sebring		190-5002360			6

NEW	Brand	Type	Note	Plug and Play	Universal harness	Remark	Photo
		Voyager CRD 2006 - 2007			190-500034W		24
		Grand Voyager 2008>		190-5002160			25
		Town & Country		190-5002160			25
		300		190-5002160			25
	Citroen	Berlingo <2006		190-500009B			8
		Berlingo 2006-2008		190-500017B			16
		Berlingo 2009>		190-500041B			16
		C1		190-5002220			11
		C2 <2006		190-500009B			1
		C2 2006-2008		190-500017B			16
		C2 2009>		190-500041B			
		C3 <2006		190-500009B			1
		C3 2006-2008		190-500017B			16
		C3 2009>		190-500041B			
		C4 <2006		190-500009B			1
		C4 2006-2008		190-500017B			
		C4 2009>		190-500041B			
		C4 Picasso 2006-2008		190-500017B			16
		C4 Picasso 2009>		190-500041B			
		C5 2001-2004		190-500009B			1
		C5 2005-2007		190-500017B			16
		C5 2008>		190-500017B			
		C5 (first generation)		190-500009B			8
		C8		190-500009B			8
		C-Crosser		190-5002360			6
		Jumper / Relay <2006		190-5002230			7
		Jumper / Relay 2006-2011		190-5002110			2
		Jumpy / Despatch <2008		190-500017B			16
		Jumpy / Despatch 2009>		190-500041B			
		Nemo		190-5002110			2
		Picasso 2006>		190-500017B			16
		Xantia			190-500009B	Installation according to the 190-500050W fitting instruction.	8
		Xsara		190-500009B			8
		Xsara Picasso		190-500009B			8
	Dacia	Duster	not for LPG/petrol versions	190-5002140			7
		Dokker		190-5002180			
		Logan Dci		190-5002140			7
		Logan Dci 2012>	not for petrol versions	190-5002180			12
		Lodgy		190-5002180			12
		Sandero I	not for 1.6 LPG/petrol versions	190-5002140			7
		Sandero II		190-5002180			12
	Daihatsu	Cuore / Mira / Domino 1.0 51KW 2011>	Engine 1KR-FE (Euro-5 !)	190-5002220			11
	Dodge	Avenger		190-5002360			6
		Caliber		190-5002360			6
		Charger		190-5002160			25
		Durango		190-5002360			6
		Grand Caravan		190-5002160			25
		Journey		190-5002360			6
		Nitro		190-5002160			25
		Ram Van CRD 2006-2007			190-500034W		24
		Ram 1500		190-5002160			25
		Ram 2500		190-5002160			25
		Ram 3500		190-5002160			25
		Viper		190-5002360			6
	Fiat	500 / 500C		190-5002380			20
		500L		190-5002130			
		Bravo <2011		190-5002110			2
		Bravo 2011>		190-5002130			3
		Croma 2005>		190-5002130			3
		Doblo I / Ram <2009		190-5002110			2
		Doblo II 2009>		190-5002130			
		Ducato <2006		190-5002230			7
		Ducato 2006-2011		190-5002110			2
		Fiorino 2008>		190-5002110			2
		Grande Punto		190-5002130			3
		Idea		190-5002110			2
		Linea		190-5002130			
		Marea 1999>			190-500225W		
		Multipla 1998>		190-5002110			2
		Panda 2003-2012	for versions with electronic throttle pedal	190-5002380			20

NEW	Brand	Type	Note	Plug and Play	Universal harness	Remark	Photo
		Panda 2012-		190-5002130			20
		Punto 2003-2009		190-5002110			2
		Punto Evo 2009>		190-5002130			3
		Qubo		190-5002110			2
		Scudo <2007		190-500009B		cut connectors from the T-harness and solder to potentiometer harness	8
		Scudo 2007-2008		190-500017B			16
		Scudo MY2009		190-500041B			
		Sedici		190-5002210			13
		Stilo 2001>		190-5002110			2
		Strada		190-5002110			2
		Ulysse <2005		190-500009B		cut connectors from the T-harness and solder to potentiometer harness	8
		Ulysse 2.2 JTD 2006>		190-500017B			16
	Ford	B-Max		190-500233A			
update		C-Max <2010	software version <A18.02	190-5002330			22
update		C-Max <2010	software version A18.07>	190-500233A			22
		C-Max / Grand C-Max 2011>		190-5002160			25
		Ecape		190-5002160			25
update		Edge	software version A18.07>		190-500248W	(10-pole throttle connector, requires firmware version 18.01 or later!)	29
		Expedition		190-5002160			25
		E150		190-5002160			25
		Fiesta 2002-2008		190-5002200			9
update		Fiesta TDCI 2009> manual gearbox	software version <A18.02	190-5002330			22
update		Fiesta TDCI 2009> manual gearbox	software version A18.07>	190-500233A			22
update		Fiesta 2009>	software version <A18.02	190-5002330			22
update		Fiesta 2009>	software version A18.07>	190-500233A			22
update		Focus 1.8TDi <2003	software version A18.07>		190-500248W	(10-pole throttle connector, requires firmware version 18.01 or later!)	29
update		Focus (Europe) 2003 - 2007	software version <A18.02, Not 1.8TDi	190-5002330			22
update		Focus (Europe) 2003 - 2007	software version A18.07>	190-500233A			22
update		Focus (Europe) 2008-2011	software version <A18.02	190-5002330			22
update		Focus (Europe) 2008-2011	software version A18.07>	190-500233A			22
		Focus (USA) 2008>		190-5002160			25
		Focus 2011>		190-5002160			25
update		Flex	software version A18.07>		190-500248W	(10-pole throttle connector, requires firmware version 18.01 or later!)	29
		Fusion (Europe)		190-5002200			9
update		Fusion (USA)	software version A18.07>		190-500248W	(10-pole throttle connector, requires firmware version 18.01 or later!)	29
update		F150 2004-2009	software version A18.07>		190-500248W	(10-pole throttle connector, requires firmware version 18.01 or later!)	29
		F150 2009-		190-5002160			25
		F250 2008-2011		190-5002160			25
		F350 2009-		190-5002160			25
		Galaxy TDI <2006		190-5002310			7
update		Galaxy 2006>	software version <A18.02	190-5002330			22
update		Galaxy 2006>	software version A18.07>	190-500233A			22
		Ka 2009-2010		190-5002380			20
update		Ka 1.2 petrol Start/Stop 2011>		190-5002130			20
update		Kuga	software version <A18.02	190-5002330			22
update		Kuga	software version A18.07>	190-500233A			22
		Mondeo <2006		190-5002330	190-500248W	diesels only	29
update		Mondeo 2007>	software version <A18.02	190-5002330			22
update		Mondeo 2007>	software version A18.07>	190-500233A			22
update		Mustang 2005-	software version A18.07>		190-500248W	(10-pole throttle connector, requires firmware version 18.01 or later!)	29
		Ranger 2.5TD & 3.0TDCI 2007-2011		190-5002320			23
		Ranger 2011>		190-5002160			25
update		S-max 2006>	software version <A18.02	190-5002330			22
update		S-max 2006>	software version A18.07>	190-500233A			22
		Taurus		190-5002160			25
		Tourneo Connect 2007>		190-500233A			22
update		Transit <2005	software version A18.07>		190-500248W		22
update		Transit 2006-2011	software version <A18.02	190-5002330			22
update		Transit 2006-2011	software version A18.07>	190-500233A			22
		Transit 2.2 TDCi 125HP 2012>	Euro-5	190-5002260			22
update		Transit 250	software version A18.07>		190-500248W	(10-pole throttle connector, requires firmware version 18.01 or later!)	29
update		Transit Connect 2006-2009	software version <A18.02	190-5002330			22
update		Transit Connect 2006-2009	software version A18.07>	190-500233A			22
		Transit Connect <2006	software version A18.07>		190-500248W	diesels only	29
		Transit Connect 2009>		190-500233A			22
	GAZ	Gazelle Business		190-5002130			3
		Siber		190-5002360			
	GMC	Acadia		190-5002390			20
		Sierra		190-5002390			20
		Youkon		190-5002390			20
	Great Wall Motors	H5 Diesel / Diesel Automatic 2011-	Use AP500 for petrol engines	190-5002110			2

NEW	Brand	Type	Note	Plug and Play	Universal harness	Remark	Photo
		Steed Diesel 2011-	Use AP500 for petrol engines	190-5002110		Speed signal: Brown/Yellow wire Pin 3 White plug at rear of instrument cluster.	2
		V200 Diesel 2011-	Use AP500 for petrol engines	190-5002110		Speed signal: Brown/Yellow wire Pin 3 White plug at rear of instrument cluster.	2
		Wingle 3/5 Diesel 2011-	Use AP500 for petrol engines	190-5002110			2
		X200 Diesel / Diesel Automatic 2011-	Use AP500 for petrol engines	190-5002110			2
	Hino	Dutro (1-1,5 tonner)		190-5002210			13
	Honda	Accord 2006-2008			190-500225W		14
		Accord 2008>		190-5002240			17
		Civic <2006			190-500225W		14
		Civic 2006-2011		190-5002240			17
		Civic MY2012		190-5002520			17
		Civic Hybrid		190-5002240			17
		Crosstour 2010>		190-5002240			17
		CR-V 2007>		190-5002240			17
		CR-V <2006			190-500225W		14
		CR-Z 2010>		190-5002240			17
		Element 2003-2010		190-5002240			17
		Fit 2009>		190-5002520			27
		FCX Clarity 2008>		190-5002240			17
		FRV			190-500225W		14
		Insight 2009		190-5002520			27
		Jazz 2002-2008			190-500225W		15
		Jazz 2009>		190-5002520			27
		Odyssey (USA) 2005>		190-5002240			17
		Pilot 2009>		190-5002240			17
		Ridgeline 2006>		190-5002240			17
	Hyundai	Accent		190-5002110			2
		Elantra 2006-2011		190-5002100			4
		Elantra 2011-		190-5002460			2
		Getz <2007		190-5002100			4
		Getz 2008> Left Hand Drive		190-5002400			2
		Getz 2008> Right Hand Drive		190-5002110			2
		Grandeur		190-5002370			6
		H1 / i800 / iLoad CRDI		190-5002110			2
		H200 CRDI		190-5002110			2
		H300 / Satellite		190-5002110			2
		i10 CRDi		190-5002400			2
		i20 CRDI Left hand drive		190-5002110			2
		i20 CRDI Right hand drive		190-5002400			2
		i40		190-5002370			6
		i800 / H1 CRDI		190-5002110			2
		iMax CRDI		190-5002110			2
		iX20 Left Hand Drive		190-5002110			2
		iX20 Right Hand Drive		190-5002400			2
		Matrix <2007		190-5002100			4
		Matrix 2008>		190-5002110			2
		Santa-Fe petrol		190-5002100			4
		Santa-Fe 2.0CRDi, 2.2CRDi 2006-2010		190-5002100			4
		Santa-Fe 2.7CRDi, 3.3CRDi 2006-2010		190-5002110			2
		Santa-Fe 2.0CDRi 2010>		190-5002370			6
		Santa-Fe 2.2CDRi 2010>		190-5002460			3
		Sonata 2.0 CRDI		190-5002370			6
		Sonata 2.4		190-5002370			6
		Terracan 2.9 CRDI		190-5002110			2
		Terracan 2.9 CRDI		190-5002100			4
		Trajet		190-5002110			2
		Trajet		190-5002100			4
		Tucson	Not for 2.7 petrol 129KW	190-5002100			4
		Veloster		190-5002460			3
	IKCO	Samand (EF7)		190-502110			2
	Isuzu	D-max / Rodeo 2009-2011	model 2012- use AP900C	190-5002480			24
		D-Max 2011-		190-5002130			2
		I-Series 2009>		190-5002480			24
		KB 2009>		190-5002480			24
		T-series 2009>		190-5002480			24
	Iveco	Turbo Daily 2006>		190-5002110			2
	Jaguar	S-Type 1998-2004	requires canbus interface for speed signal		190-500225W		7
		X-type 2001-	requires canbus interface for speed signal		190-500225W		7

NEW	Brand	Type	Note	Plug and Play	Universal harness	Remark	Photo
	Jeep	Cherokee 2.8 CRD			190-500225W		
		Cherokee 2008- Commander		190-5002160	190-500225W		25
		Compass		190-5002160			25
		Liberty		190-5002360			6
		Patriot		190-5002160			25
		Wrangler 2008->		190-5002360			6
				190-5002160	190-500225W		25
	Kia	Carens <2005		190-5002100			4
		Carens 2006-2012		190-5002370			6
		Carens 2012- Carnival 2.9 CRDi		190-5002400			4
		Carnival 2.9 CRDi		190-5002100			4
		Carnival 2.9 CRDi		190-5002110			2
		Cee'd 2006-2012 manual transmission		190-5002110			2
		Cee'd 2006-2012 automatic transmission		190-5002110			2
		Cee'd 2013- Cerato		190-5002460			3
		Cerato		190-5002110			2
		Magentis 2006->		190-5002370			6
		Picanto <2007		190-5002100			4
		Picanto 2008-2010		190-5002110			2
		Picanto 2011>		190-5002400			2
		Pro-Ceed		190-5002110			2
		Rio <2007		190-5002110			2
		Rio 2007-2011		190-5002400			2
		Rio 2011>		190-5002460			2
		Soul		190-5002400			2
		Soul 2010> diesel		190-5002110			2
	Sorento <2005		190-5002100			4	
	Sorento 2006-2009		190-5002110			2	
	Sorento 2009> manual transmission		190-5002460		from 2011 onwards needs PULL-UP on speed signal	3	
	Sorento 2009 > automatic transmission		190-5002460		from 2011 onwards needs PULL-UP on speed signal	3	
	Sportage CDRI (2004-2009)		190-5002110			2	
	Sportage 2010>		190-5002370			6	
	Venga		190-5002400			2	
	Lancia	Delta 2008>		190-5002110			2
		Lybra 1.9 JTD		190-5002110			2
		Musa		190-5002110			2
		Ypsilon 2006>		190-5002380			20
	Land Rover	Defender Td-4 (2007>)		190-5002510			
		Defender Td-5 (2002-2007)	Requires specific firmware!!	190-5002500			
		Discovery 3 (2004-2010)			190-500225W		
		Freelander (1997-2003)			190-500225W		
		Freelander (2003-2006)		190-5002200			9
		Freelander 2 (2007>)		190-5002330			22
NEW	Lamborghini	834 Aventador		190-5002450			
	Lexus	IS <2011		190-5002210			13
		IS 2011>		190-5002220			11
	LDV	Maxus		190-5002230			7
	Mahindra	Scorpio (GOA)		190-5002110			2
		Pikup			190-500225W		
	Mazda	2 <2007		190-5002200			9
		2 Petrol 2007-2010		190-5002220			11
update		2 CiTD 2008-2010	software version <A18.02	190-5002330			22
update		2 CiTD 2008-2010	software version A18.07>	190-5002330			22
		2 2011-	all models	190-5002220			
update		3 2004-2009	software version <A18.02	190-5002330			22
update		3 2004-2009	software version A18.07>	190-5002330			22
		3 2009-2011			190-500233W		25
		3 Petrol , 1.6CiTD 2011-2013		190-5002160			25
		3 MY2013		190-5002160			25
		5 CiTD 2005-2010		190-5002210			13
update		5 Petrol 2008-2010	software version <A18.02	190-5002330			22
update		5 Petrol 2008-2010	software version A18.07>	190-5002330			22
update		5 1.6 CiTD 2011-	software version <A18.02	190-5002330			22
update		5 1.6 CiTD 2011-	software version A18.07>	190-5002330			22
	5 Petrol 2011-		190-5002160				
	6 <2007		190-5002210			13	

NEW	Brand	Type	Note	Plug and Play	Universal harness	Remark	Photo
		6 2008>		190-5002160			<u>25</u>
		Axela MY2013	(a.k.n.a. Mazda 3)	190-5002160			
		B2500		190-5002320			<u>23</u>
		BT-50 2.5TDI &3.0 CRDi <2011		190-5002320			<u>23</u>
		BT-50 2011-		190-5002160			
		CX5		190-5002530			
		CX7		190-5002220			<u>11</u>
		MPV		190-5002320			<u>23</u>
		MX5 2006>		190-5002210			<u>13</u>
		RX8		190-5002210			<u>13</u>
	Mercedes	A Class <2012		190-5002490			<u>18</u>
		B Class (245) 2005-2011		190-5002490			<u>18</u>
NEW		B Class (246) 2011-	Use AP900Ci or CAN-bus interface for speed signal	190-5002440			
		Citan		190-5002180			
		C-Class (203) <2007		190-5002490			<u>18</u>
		C-Class (204) 2007>		190-5002440			<u>21</u>
		E-Class (211) 2002-2009		190-5002490			<u>18</u>
		E-Class (212) 2009>		190-5002440			<u>21</u>
		G-Class 2009-		190-5002490			<u>18</u>
		Sprinter 1995-2000	(5-pole throttle connector)		190-500225W		
		Sprinter (901-904) 2000-2006	(5-pole throttle connector)		190-500225W		<u>18</u>
		Sprinter (906) 2006>		190-5002440			<u>21</u>
		Vaneo		190-5002490			<u>18</u>
		Viano CDI		190-5002490			
		Vito 1996-2006		190-5002490			<u>18</u>
		Vito 2006>		190-5002440			<u>21</u>
	Mini	Mini 2001>		190-5002470			<u>18</u>
update	Mitsubishi	Canter 2008-2010	not for EURO-5 engines		190-500234W		
update		Canter 2010-2011	EURO-5 engines		190-500234X		
		Canter 2012>			190-500225W		
		Carisma DI-D 2001>		190-5002140			
		Colt (2005>)		190-5002130			<u>3</u>
		Grandis 2.0 DI-D			190-500225W		<u>13</u>
		Grandis 2.4 MPI			190-500225W		<u>13</u>
		Lancer 2008>		190-5002360			<u>6</u>
		L200 2005-		190-5002290			<u>13</u>
		Outlander 2007>		190-5002360			<u>6</u>
		Pajero 2006>		190-5002290			<u>13</u>
update		Shogun 2006>	Not for Shogun Spot Turbo Diesel	190-5002290			<u>13</u>
		Space Star -2012		190-5002140			
NEW		Space Star 2013-		190-5002210			<u>13</u>
		Triton 2005-		190-5002290			<u>13</u>
update	Nissan	Almera	Not for 2.2VDI	190-5002130			<u>3</u>
		Almera Tino		190-5002130			<u>3</u>
		Altima 2007>		190-5002180			<u>12</u>
		Cabstar F24 2007>		190-5002180			<u>12</u>
		Cube		190-5002180			<u>12</u>
		Interstar		190-5002140			<u>7</u>
		Juke		190-5002180			<u>12</u>
		Frontier		190-5002130			<u>3</u>
		Kubistar		190-5002140			<u>7</u>
		Maxima		190-5002180			<u>12</u>
		Maxity		190-5002180			<u>12</u>
		Micra 2003>		190-5002180			<u>12</u>
		Murano 2008>		190-5002180			<u>12</u>
		Navara 2005>		190-5002130		Speed pulse Navara 2011>: combi-instrument panel connector, pin no. 5 (no pull-up) !!	<u>3</u>
		Note		190-5002180			<u>12</u>
		NP300		190-5002130		190-5002120 (diesel)	<u>12</u>
		NV200 Petrol	use AP900C for Dci versions	190-5002180			<u>12</u>
NEW		NV400		190-5002180			<u>12</u>
		Pathfinder		190-5002130			<u>3</u>
		Patrol 2007>		190-5002180			<u>12</u>
		Pixo		190-5002210			<u>13</u>
		Primastar		190-5002140			<u>7</u>
		Primera		190-5002130			<u>3</u>
		QashQai 2007>		190-5002180			<u>12</u>
NEW		Sentra 2013> (Sylphy, Pulsar)		190-5002180			<u>12</u>
		Teana		190-5002180			<u>12</u>
		Tiida		190-5002180			<u>12</u>
update		X-trail 2004-2007	Not for 2.2VDI	190-5002120			<u>5</u>
		X-Trail 2007>		190-5002180			<u>12</u>

NEW	Brand	Type	Note	Plug and Play	Universal harness	Remark	Photo
		350Z		190-5002120			5
		370Z		190-5002180			
	Opel	Agila 2003-2007		190-5002130			3
		Agila 2008>		190-5002210		Speed pulse. Manual gearbox: brown wire Power Steering module (blue) connector (behind mid-console, right side). Automatic gearbox: TCM 26-pole connector, pin 25 purple wire (A-style passenger side)	13
		Antara		190-5002390			20
		Astra G (1998-2004)			190-500225W		
		Astra H (2004-2009)		190-5002130			3
		Astra J (2009>)		190-5002130			3
NEW		Combo 2012>		190-5002130			3
		Combo 2004-2012		190-5002130			3
		Corsa 2000>		190-5002130			3
		Frontera			190-500225W		
		Meriva 2004-2010		190-5002130			3
		Meriva B (2010>)		190-5002390			20
NEW		Mokka 2012>		190-5002130			
		Movano A <2010		190-5002140			7
		Movano B 2010>		190-5002180			12
		Vauxhall Movano B 2012>		190-5002430			12
		Tigra Twin-top		190-5002130			3
		Tour		190-5002130			3
		Vectra B		190-5002130			3
		Vectra C		190-5002130			3
		Vivaro 2006>		190-5002140			7
		Vivaro <2006		190-5002140			7
		Zafira <2005			190-500225W		
		Zafira 2005>		190-5002130			3
	Peugeot	107 <2007		190-500009B			16
		107 Petrol 2008>	1.0 petrol may be cable driven	190-5002220			11
		1007 (2005-2006)		190-500009B			1
		1007 (2006>)		190-500017B			16
		206 (first generation)		190-500009B		cut connectors from the T-harness and solder to potentiometer harenss	8
		206/SW/CC (2005-2006)		190-500009B			1
		206 2006>		190-500017B			16
		207 (2006-2008)		190-500017B			16
		207 2008>		190-500041B			26
NEW		208 2012-		190-500041B			26
		306 HDI		190-500009B		cut connectors from the T-harness and solder to potentiometer harenss	8
		307 (first generation)		190-500009B		cut connectors from the T-harness and solder to potentiometer harenss	8
		307/SW/CC (2005-2006)		190-500009B			1
		307 2006>		190-500017B			16
		308 <2008		190-500017B			16
		308 2009>		190-500041B			26
		3008		190-500041B			26
		406 HDI		190-500009B		cut connectors from the T-harness and solder to potentiometer harenss	8
		407/SW/Coupe (2005-2006)		190-500009B			1
		407/SW/Coupe (2006-2008)		190-500017B			16
		407 2008>		190-500041B			26
		4007		190-5002360			6
		5008		190-500041B			26
		806 HDI		190-500009B		cut connectors from the T-harness and solder to potentiometer harenss	8
		807		190-500009B		cut connectors from the T-harness and solder to potentiometer harenss	8
		807 2.0 2008>		190-500017B			16
		Bipper		190-5002110			2
		Boxer <2006		190-5002230			7
		Boxer 2006-2011		190-5002110			2
		Expert <2007		190-500009B		cut connectors from the T-harness and solder to potentiometer harenss	8
		Expert 2008>		190-500041B			26
		Partner (2005-2006)		190-500009B		cut connectors from the T-harness and solder to potentiometer harenss	8
		Partner 2006-2008		190-500017B			16
		Partner 2009>		190-500041B			26
	Porsche	911/997 2004-2008		190-5002230			7
		911 2008>			190-500225W		
		966 MY2000			190-500225W		
		Boxster			190-500225W		
		Boxster S			190-500225W		
		Cayenne		190-5002230			7
	Renault	Avantime		190-5002140			7
		Scénic 08-2003>		190-5002180			12
		Clio II 2001-2005		190-5002140			7

NEW	Brand	Type	Note	Plug and Play	Universal harness	Remark	Photo
		Clio III 2005>		190-5002180			12
		Espace		190-5002140			7
		Fluence		190-5002180			12
		Kangoo 2003-2008		190-5002140			7
		Kangoo 2008>		190-5002180			12
		Koleos		190-5002180			12
		Laguna 2001-2005		190-5002140			7
		Laguna 2006>		190-5002180			12
		Laguna 2.0 dCi 2011>	only 2.0dCi	190-5002150			12
NEW		Latitude 2010>		190-5002180			
NEW		Latitude 2.0 dCi 2010>	only 2.0dCi	190-5002150			
		Master 2003-2010		190-5002140			7
		Master 2010>		190-5002180			12
		Master 2012> (right hand drive)		190-5002430			12
		Maxity		190-5002180			12
		Mégane 03>		190-5002180			12
		Mégane 03> Automatic		190-5002180			12
		Modus / Grand Modus		190-5002180			12
		Symbol III Dci 2012>		190-5002180			12
		Trafic		190-5002140			7
		Thalia / Symbol II 2008-2012		190-5002140		Skontrolovat' či má elektronický pedál!	7
		Twingo 1996-2007		190-5002140			7
		Twingo 1.2 16V 2007>		190-5002430			12
		Vel Satis		190-5002140			7
	Saab	9-3 2002>		190-5002130			3
update	Seat	Alhambra <2010		190-5002230			7
update		Alhambra 1.9TDI <2010		190-5002310			7
update		Alhambra 2010>		190-5002450			
		Altea 2004>>		190-5002450			10
		Arosa 2002-2004		190-5002230			7
		Arosa 1.4TDI 2002-2004		190-5002310			7
		Cordoba		190-5002230			7
		Cordoba 1.4TDI		190-5002450			7
		Cordoba 1.9TDI		190-5002310			
		Exeo		190-5002450			
		Ibiza 2002-2008		190-5002230			7
		Ibiza 1.4TDI, 1.9TDI 2002-2008		190-5002310			7
		Ibiza 2008>		190-5002230			7
		Leon 2002-2005		190-5002230			7
		Leon 1.9TDI 2002-2005		190-5002310			7
		Leon 2005>		190-5002450			10
		Toledo <2004		190-5002230			7
		Toledo 1.9 TDI <2004		190-5002310			7
		Toledo 2004>		190-5002450			10
	Skoda	Fabia 2000> petrol + 1.6TDI		190-5002230			7
		Fabia 2000> 1.4TDI, 1.9TDI		190-5002310			7
		Octavia 1U petrol <2004		190-5002230			7
		Octavia 1U 1.9TDI <2004		190-5002310			7
		Octavia 1Z 2004>		190-5002450			10
update		Praktik petrol + 1.6TDI		190-5002230			7
update		Praktik 1.4TDI, 1.9TDI		190-5002310			7
update		Praktik 2011>		190-5002450			
		Roomster petrol + 1.6TDI		190-5002230			7
		Roomster 1.4TDI, 1.9TDI		190-5002310			7
		Roomster 2011>		190-5002450			
		Superb 1.4TSI 92KW		190-5002450			10
		Superb 1.6TDI 77KW		190-5002450			
		Superb 1.8T (not AGU) 110KW		190-5002230			
		Superb 1.8 TSI 118WK		190-5002450			
		Superb 1.9TDI 77KW		190-5002310			
		Superb 2.0 85KW		190-5002230			
		Superb 2.0TDI 103KW		190-5002450			
		Superb 2.0TDI 125KW		190-5002450			
		Superb 2.0TDI 103KW		190-5002230			
		Superb 2.0TSI 147KW		190-5002450			
		Superb 2.8 V6 142KW		190-5002230			
		Superb 3.6FSI 191KW		190-5002450			
		Yeti		190-5002450			
	Smart	ForFour		190-5002130			3
		ForTwo <2007			190-500225W		2
		ForTwo 2007>		190-5002440			21

NEW	Brand	Type	Note	Plug and Play	Universal harness	Remark	Photo
		Roadster 2006>					
	Ssang Yong	Actyon A200 Xdi		190-5002110			2
		Actyon A230		190-5002110			2
		Korando 2010-		190-5002110			
		Kyron M200Xdi		190-5002110			2
		Rexton 2006>		190-5002110			2
		Rexton 230			190-500225W		18
		Rexton 270		190-5002110			2
		Rodius 270		190-5002110			2
	Subaru	Forester 2.0		190-5002220			11
		Forester 2008>		190-5002220			11
		Impreza 2005>		190-5002220			11
		Legacy 2003>			190-500225W		13
update		Outback Sport		190-5002220			
		Tribeca					
		Trezia		190-5002280			28
update		WRX STI		190-5002220			
NEW		XV		190-5002220			
	Suzuki	Alto 2009>		190-5002210			13
		Alto 1.0 Automatic		190-5002210			13
update		Grand Vitara <2006			190-500009W		8
		Grand Vitara 2006>		190-5002210		for speed pulse input use brown wire from the power steering module (blue) connector (behind mid-console, right side)	13
		Ignis 1.3 Diesel		190-5002130			3
		Jimny 1.5 DSL		190-5002460			3
update		Liana			190-500009W		8
		Splash		190-5002210		for speed pulse input use brown wire from the power steering module (blue) connector (behind mid-console, right side)	13
		Swift Diesel 2005-2008		190-5002130			3
		Swift Diesel 2008>		190-5002210		for speed pulse input use brown wire from the power steering module (blue) connector (behind mid-console, right side)	13
		Swift Petrol 2005-2008		190-5002210			13
		Swift Petrol 2008>		190-5002210		for speed pulse input use brown wire from the power steering module (blue) connector (behind mid-console, right side)	13
		SX4 1.6		190-5002210			13
		Wagon R 1.3 DDiS 51KW		190-5002130			3
NEW	Tata	Vista		190-5002110			
	Toyota	Avalon 2008>		190-5002220			11
		Avensis < 2008		190-5002120			5
		Avensis Verso < 2008		190-5002120			5
		Avensis 2009 >		190-5002220			11
		Aygo <2007		190-500009A			1
		Aygo MMT 2006-2007		190-5002220			11
		Aygo Petrol 2008>		190-5002220			11
		Auris 2007-2012		190-5002220			11
NEW		Auris 2013-		190-5002280			28
		Camry 2001-2005		190-5002120			5
		Camry 2006>		190-5002220			11
		Corolla <2007		190-5002120			5
		Corolla 2007>		190-5002220			11
		Corolla Verso		190-5002120			5
NEW		Dyna 100, 150, 200, 250 (Y-200 series)		190-5002210			13
		Hi-ace		190-5002120			5
		Hi-lux <2005		190-5002120			5
		Hi-lux 2005>		190-5002210			13
		IQ		190-5002220			11
		Land Cruiser 90		190-5002120			5
		Land Cruiser 100 2005>		190-5002210			13
		Land Cruiser 120 2003>		190-5002210			13
		Land Cruiser 150 Prado 2005-2009		190-5002210			13
		Land Cruiser 150 Prado 2009>	manual gearbox	190-5002220			11
		Land Cruiser 200 4.0 V6 petrol 2007>	Use AP500 for all other model variants	190-5002220			11
		Matrix 2009>		190-5002220			11
		Prius 2011>		190-5002220			11
		Prius 2005-2010		190-5002210			13
		Prius 2001-2004		190-5002120			5
		Previa 2000>		190-5002120			5
		Raider		190-5002210			13
		RAV4 <2006		190-5002120			5
		RAV4 2006-2012		190-5002220			11
NEW		RAV4 2013-		190-5002280			28
		Sienna 2003>		190-5002210			13
		Sienna 2011>		190-5002220			11
		Urban Cruiser		190-5002220			11

NEW	Brand	Type	Note	Plug and Play	Universal harness	Remark	Photo
		Verso		190-5002220			11
		Verso S		190-5002280			28
		Yaris D4D 1998-2006		190-5002120			5
		Yaris 2006-2011		190-5002220		mount Clutch Switch	11
		Yaris 1.0 (MMT) 2006>		190-5002220			11
		Yaris MY-2012		190-5002280			28
	UAZ	Cargo		190-5002110			2
		Patriot		190-5002110			2
		Pickup		190-5002110			2
	Volkswagen	Amarok		190-5002230			7
		Beetle		190-5002450			10
		Bora		190-5002230			7
		Bora 1.9TDI		190-5002310			7
		Caddy 2004>		190-5002450			10
		Caravelle		190-5002230			7
		Caravelle 1.9 & 2.5 TDI		190-5002310			7
		Crafter 06>		190-5002440			21
		EOS		190-5002450			10
		Fox 1.2, 1.4 2005>		190-5002230			7
		Golf 4		190-5002230			7
		Golf 4 1.9TDI <2003		190-5002310			7
		Golf 5 (Plus) 2003>		190-5002450			10
		Golf 6		190-5002450			10
		Jetta 2005>		190-5002450			10
		Multivan 2003-2009	Use AP900C for 2009> models!	190-5002230			7
		Multivan 1.9 & 2.5 TDI 2003-2009	Use AP900C for 2009> models!	190-5002310			7
		Multivan 2009-		190-5002450			10
		Passat 2000-2005		190-5002230			7
		Passat 1.9&2.5 TDI 2000-2005		190-5002310			7
		Passat 2005>		190-5002450			10
		Polo 1.4TDI, 1.9TDI 2002>		190-5002310			7
		Polo 1.2TDI 2002>		190-5002230			10
		Polo Petrol 2002>		190-5002230			10
		Lupo		190-5002230			7
		Lupo 1.4TDI & 3L 1.2TDI		190-5002310			7
		Scirocco 2008>		190-5002450			10
		Sharan 2000>		190-5002230			7
		Sharan 1.9TDI 2000>		190-5002310			7
		Sharan 2.0 TDI 2000>		190-5002450			7
		Tiguan		190-5002450			10
		Touareg 2002>		190-5002230			7
		Touran 2003-2006		190-5002230			7
		Touran 1.9TDI 2003-2006		190-5002310			7
		Touran 2006>		190-5002450			10
		Transporter 5 2003-2009	Use AP900C for 2009> models!	190-5002230			7
		Transporter 5 2003-2009 1.9 & 2.5 TDI	Use AP900C for 2009> models!	190-5002310			7
		Up!		190-5002450			10
	Volvo	C30		190-5002330	2008>		22
		S40		190-5002330			22
		V50		190-5002330			22
		C70		190-5002330			22
		V70 2007>		190-5002330			22
		XC60 2009>		190-5002330			22
		XC70 2007>		190-5002330			22
		S80 2006>		190-5002330			22

Photo:

1

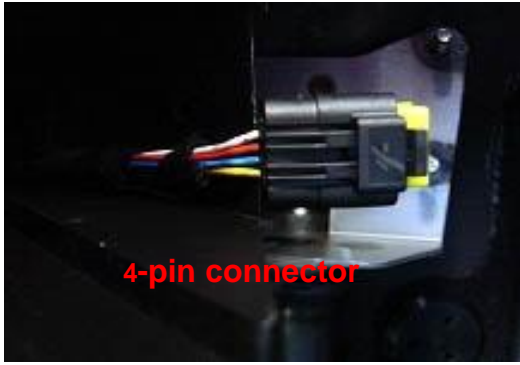

Peugeot - Citroen
W/H AP800 Part no:

190-5000090

Plug and Play available

2



Fiat
Hyundai
Iveco
Ssang Yong
Kia
UAZ

3



Nissan
Mitsubishi
Fiat
Suzuki

4



Kia
Hyundai

5



Toyota
Nissan

6



Hyundai Sonata 2.4
Chrysler Sebring
Dodge Avenger, Caliber
Mitsubishi Outlander, Lancer
Peugeot 4007
Citroen C-Crosser

7

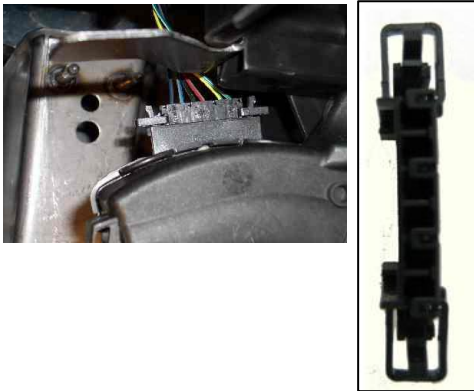

Renault
Opel
Nissan
Peugeot
Citroen
VW
Audi

8

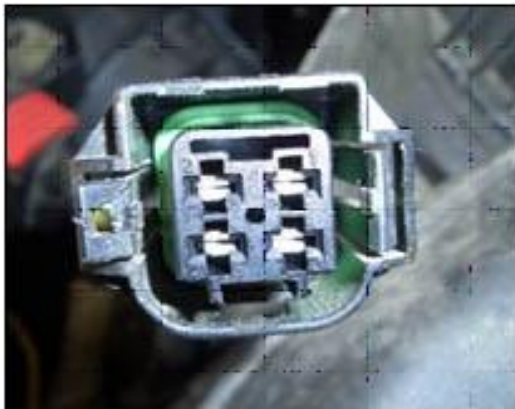

Peugeot Potentiometer under bonnet
Citroen Potentiometer under bonnet
Suzuki Potentiometer under bonnet

W/H AP800 Part no: 190-500050W

9

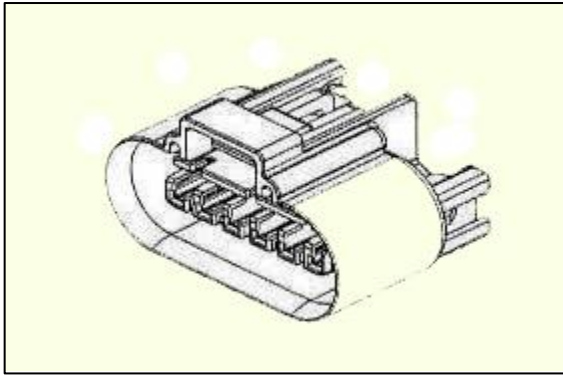

Ford Fiesta
Land Rover freelande
Mazda-2

10



VW Golf 5
VW Passat 2005>

11



New Toyota;
Aygo
Yaris
RAV4 2006>

Mazda:
2, 6, CX7

Subaru

12



Renault:
Modus
Mégane
Scenic

Nissan:
Cabstar

Dacia:
Lodgy

13

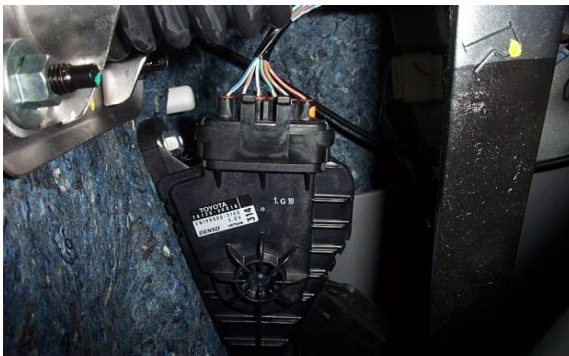

Mazda:
6
MX5 (2006)
RX8

Toyota
Raider (Hi-lux)

Mitsubishi
Grandis, L200, Pajero

14



Honda

CRV/HRV

W/H AP800 Part no:
190-5000510

15



Honda
Jazz

16



Citroen, Peugeot

17



Civic 2006>
CRV 2007>

18

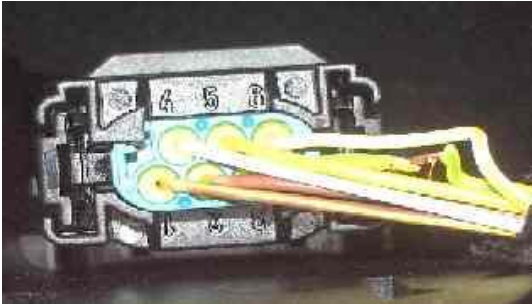

BMW 118
Mercedes A, B, Sprinter
Mini
SsangYong Rexton 230

19



PT Cruiser 2000-2006

20



Fiat Panda
Fiat 500
Lancia Ypsilon

21

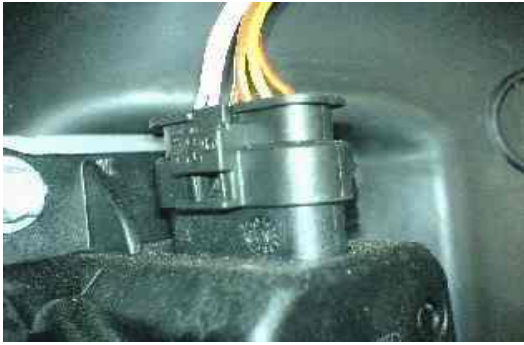

Mercedes

C-class
Sprinter
Vaneo
Viano
Vito

VW

Crafter

22



Ford:

C-Max
Focus 2004>
Galaxy 2006>
Mondeo 2007>
S-Max 2006>
Transit 2006>
Transit Connect 2007>

Volvo

C30
S40
V50
C70
V70
S80

Mazda

3

LandRover

Freelander 2

23



Ford

Ranger

Mazda

BT-50

24



Chrysler

Voyager CRD

Dodge

Ram Van

Isuzu

D-Max

Chevrolet

Colorado / D-Max

25

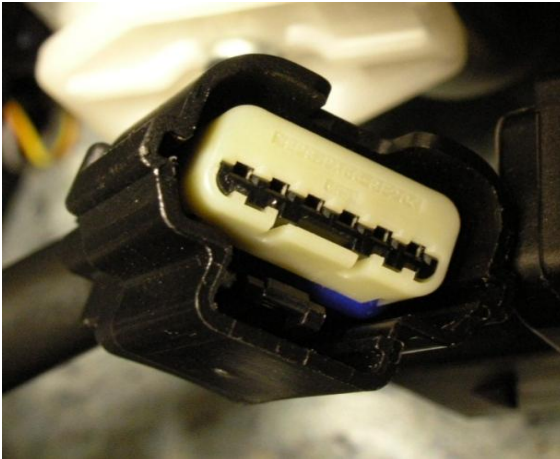

Chrysler

Grand Voyager

Dodge

Nitro

Ford

Focus USA

Focus 2011-

C-Max 2011- / Grand C-Max

Mazda

3, 6

Chevrolet

Spark

Jeep

Wrangler

26



Fiat

Scudo

Peugeot

Citroen

27



Honda
Jazz
Fit
Insight

28



Toyota
Verso-S

Subaru
Trezia

29



Ford
Edge
Flex
Fusion (USA)
Transit 125T 350 (EU)
F150
F350

Range Rover